HOW TO NOTES

Helpful hints to get the most out of your ELF

ADVANCED CONFIGURATION FOR THE ELF – Custom control for Merry Christmas sign.

1. INTRODUCTION

This How To Note describes how to set up the hardware and configure the software to allow the ELF to control a sign that lights up the word “Merry Christmas” in a consecutive sequence. It describes how to do it using one strand of 240 lights.

In this example, 15 lights will be used to make up each of the letter in the word “Merry”, with the remaining 165 lights used to make up the word “Christmas”. The light sequence will be all letters off, then “M”, followed by “Me”, followed by “Mer”, etc. After the word “Merry” has been lit, the full word “Christmas” will light up. The two word will remain lit for a little while before the sequence starts again.

2. HARDWARE

“Merry Christmas” Light Design

Christmas lights are configured in what is called a series – parallel set up. A typical string of 240 globes is actually made up of 16 sets of 15 globes.

Below is 2 set of 4 lights representing the last 2 sets in a string of lights. It shows how they are wired together. The following instructions tell how to ‘break’ the set of lights into smaller sets.

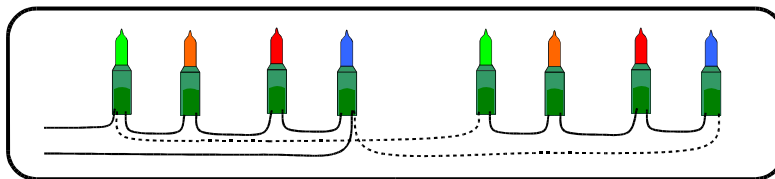

Figure 1 - Strand of Christmas lights

- 2.1 Using the above diagram as a guide, find the last globe in the “second last” set. It will have 3 wires coming from the base of it, 2 heading toward the transformer and 1 heading toward the last set of lights. If the set of lights is 240 and is made up of 16 lots of 15 lights, then the last light in the “second last” set will be the 16th from the end.
- 2.2 Remove the bulb as per the manufacturer’s instructions on changing bulbs.

- 2.3 The diagram below shows how the wires fit into the globe holder. Using a small set of pliers, pull the two wires up out of the globe holder. Push the wire that heads toward the transformer back into place. Push the wire that heads toward the last set of globes down through the middle of the globe holder, totally removing it.

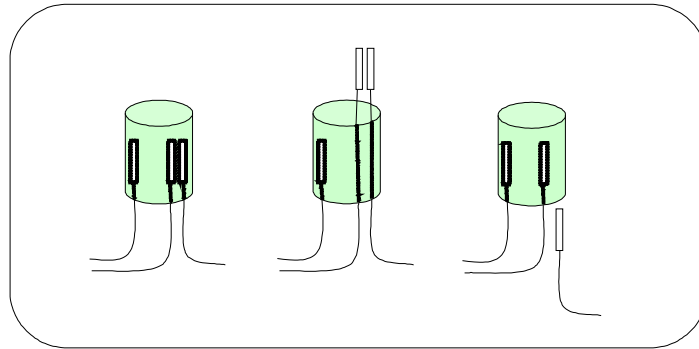

Figure 2 - Disconnecting from last of "second last" set

- 2.4 Repeat the process for the first globe holder in the "second last" set, using the diagram below as a guide.

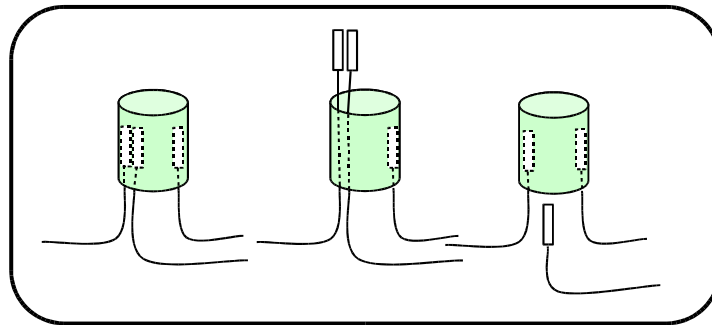

Figure 3 - Disconnecting from first of "second last" set

- 2.5 The last set of lights will now be disconnected from the full strand. Cut and strip 5mm of insulation from the ends of the cables and plug them into the orange screw terminals supplied with the ELF.

Note: You may need to add more wire to the ends as the ELF controller may not be stored close enough to where you want the display.

2.5 Using a length of wire, create the desired letter or word. Using tape, bind the lights to the wire letter. Use individual strands for each of the letters in the word “Merry” and one set for the word “Christmas”. Below is an example of the letter “M”.

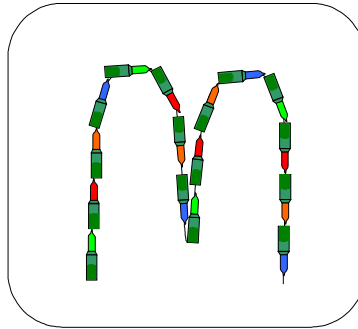

Figure 4 – Lights bound to wire “M”

2.6 On the ELF controller box, use the connection table below.

Light Letter	Channel
M	1
e	2
r	3
r	4
y	5
Christmas	6

Table 1 – Channel allocation

2.7 The connections of the “light letters” to the ELF controller box will be as shown in the figure below. In the figure, each light represents a “light letter”.

Note: Make sure the connectors are commoned together as shown in the figure. If the wrong side of the connectors are commoned, the lights will not flash.

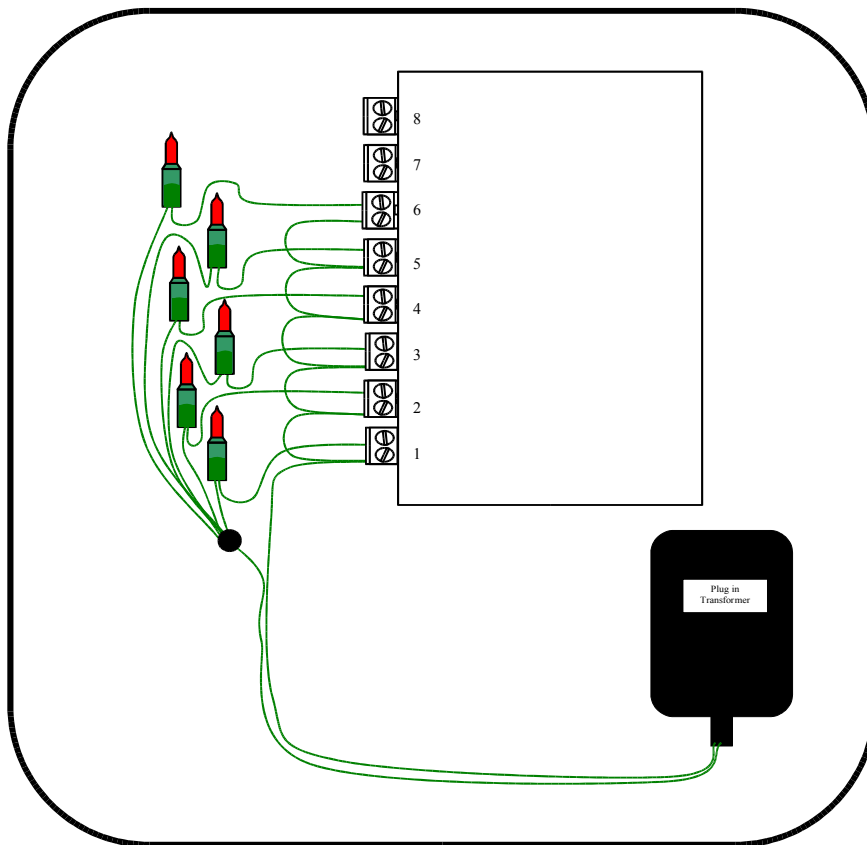

Figure 5 – Light connections

Once the “light letters” have been created the ELF controller box needs to be programmed.

3. Connection to the ELF controller box

The ELF can control up to eight different strands of lights. Each strand of lights connect to a plug. Each plug connects into a channel. Before the strands of lights can plug into the ELF controller box, the wiring needs to be modified. The *How To - 8 strands of flashing lights* note shows how to do this.

4. Programming the ELF controller box

To program the ELF controller box, disconnect the light strands from the box and take the box, the power supply and the communications lead to a convenient location next to the computer that has the ELF software installed.

Note: the lights can be left connected while the ELF controller box is programmed.

- 4.1 Open the ELF software program and connect to the ELF controller box. Set up channels 1 to 6 as “Custom” as shown below.

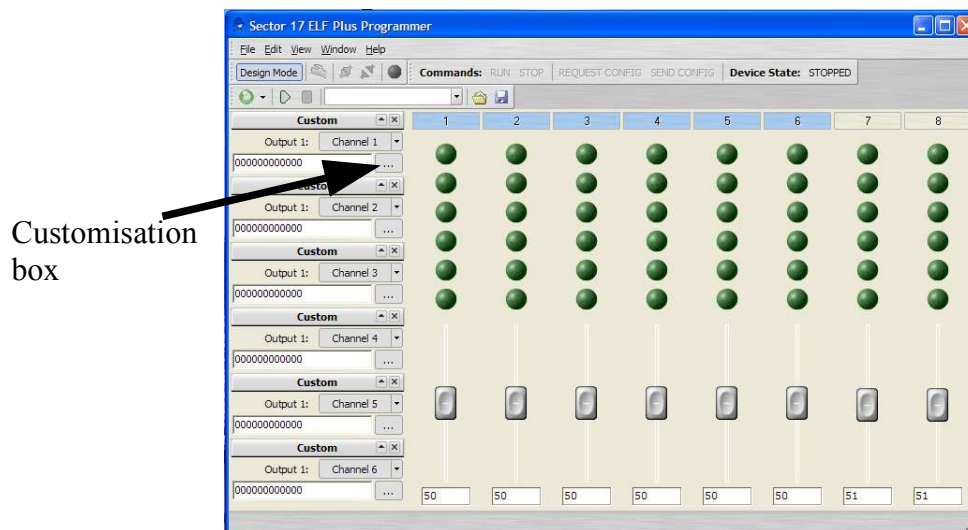

- 4.2 The *Custom* light sequence needs to be customised to create the correct effect. Click on the box with the 3 dots in it which is located below the Channel number. A box similar to the one shown below will pop up.



- 4.3 In the picture above, the green dots show when the lights will be on and off. The dots turn on and off by clicking on them. Channel one needs to be set up as On, Off, Off, Off, Off, Off, Off, Off, Off, Off, Off, Off. This is shown below.



- 4.4 Click OK when the channel mask is set.

4.5 The table below show the masks for all the channels.

	Sequence											
Channel	1	2	3	4	5	6	7	8	9	10	11	12
1	On	On	On	On	On	On	On	On	On	On	On	Off
2	Off	On	On	On	On	On	On	On	On	On	On	Off
3	Off	Off	On	On	On	On	On	On	On	On	On	Off
4	Off	Off	Off	On	On	On	On	On	On	On	On	Off
5	Off	Off	Off	Off	On	On	On	On	On	On	On	Off
6	Off	Off	Off	Off	Off	On	On	On	On	On	On	Off

4.6 Using the simulator, choose a flash delay that is appropriate. Make sure that all the flash delays for channels 1 to 6 are exactly the same.

4.7 To save the effect into the ELF controller box, click on the **Send Config** button on the main menu.

The programming is now complete.

Turn off the power to the ELF controller box and disconnect it from the computer. The configuration is stored in the ELF controller box and doesn't need power to be connected to remember the settings. Take the ELF back and plug in the strands of lights. Turn on the power to the lights and the ELF controller box and the lights will flash in the configuration that was set up with the ELF software.

If a change is required, simply follow the procedure in step 3.1 to 3.3 and 3.6. After step 3.6 select **REQUEST CONFIG** from the menu bar. The current configuration in the ELF controller box will be displayed on the screen. Changes can be made. For example, the flash delay on channel 5 may need to be increased to 60. Move the slider or type in the number. Once the changes have been made, simply select **SEND CONFIG** from the main menu and then move the ELF controller box back and plug in the lights.

For full instructions on using the program, select *Help* from the menu bar at the top.

Young Control Systems www.ycsys.com.au